

- NOTES:
1. BLACK "TURTLE TILE" DECKING SHALL BE INSTALLED IN EACH COMPARTMENT
 2. THE "TURTLE TILE" DECKING SHALL HAVE A 2" DEEP BLACK TAPERED EDGE BETWEEN THE COMPARTMENT DOOR AND THE FRONT EDGE OF THE DECKING
 3. STAINLESS STEEL HIGH HATS AND LUG NUT COVERS SHALL BE INSTALLED ON CHASSIS WHEELS
 4. THE CHASSIS EXHAUST SYSTEM SHALL REMAIN AS SUPPLIED FROM CHASSIS MFG

(1) NEWTON #6012SW-34, 10" STAINLESS STEEL 90° ADAPTER SHALL BE SUPPLIED

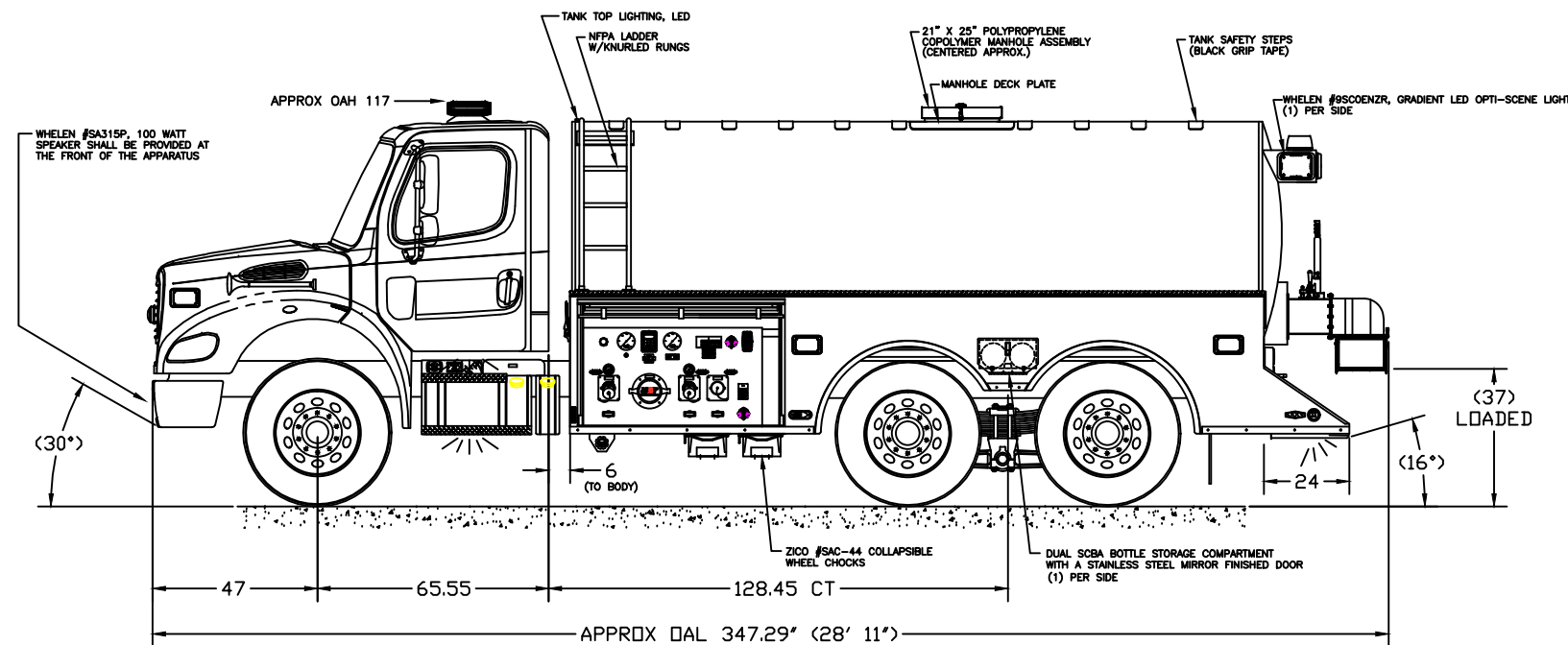

NOTE: PUMP PANEL LAYOUT SHOWN IS FOR REFERENCE ONLY

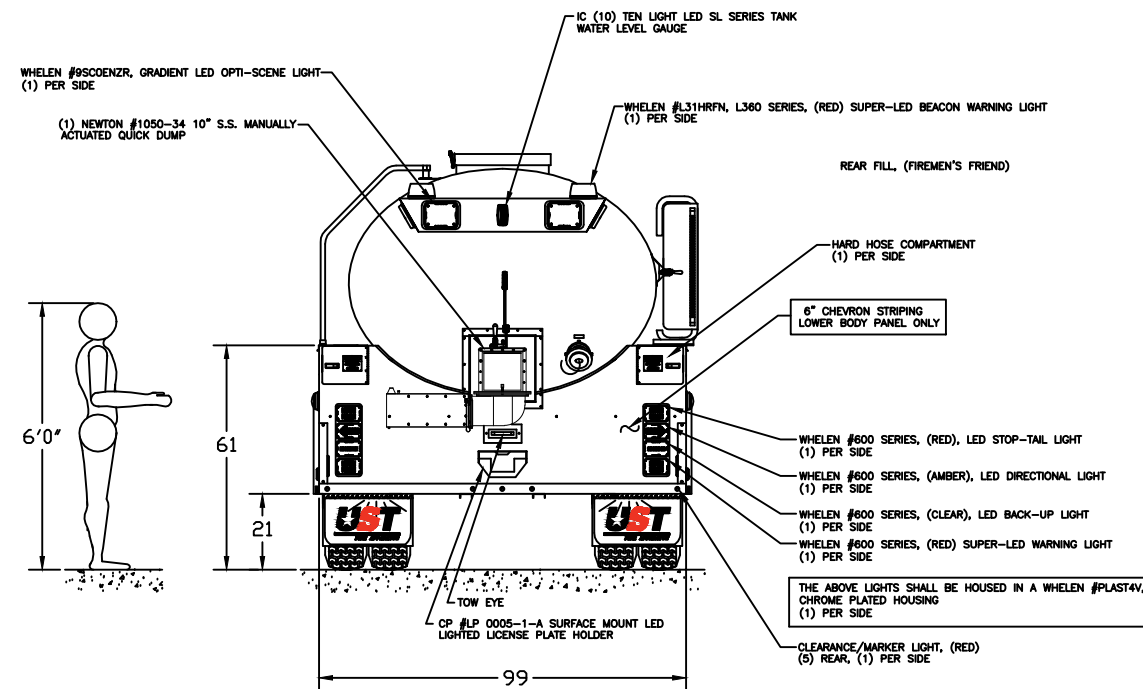

COMPARTMENTATION	INSIDE DIMENSIONS		
	WIDTH	HEIGHT	DEPTH
STREET/CURB - FRONT	60"	37.5"	27"

CUSTOMER APPROVAL		CUSTOMER	STOCK PROGRAM-- (SMEAL)
THIS DRAWING IS ONLY A REPRESENTATION OF THE PRODUCT. EXACT LOCATION OF COMPONENTS MAY DIFFER DUE TO MANUFACTURING/SUPPLIER CHANGE. WRITTEN SPECIFICATIONS SUPERSEDE PRINTS		SIZE	3000 GALLON
SIGNATURE _____		TANK MATERIAL	POLYPROPYLENE COPOLYMER
TITLE _____		BODY MATERIAL	STAINLESS STEEL
DATE _____		CROSS SECTION	61" X 83" X 192" LG
CONCEPT <input type="checkbox"/> ORDER <input checked="" type="checkbox"/>		AFTERFRAME	72"
PROPOSAL <input type="checkbox"/> UST#UXXXX		PUMP	HALE AP 500 GPM (PTO)
		CHASSIS	FREIGHTLINER M2112
		DRAWN BY	JLB DATE 12/14/15
THIS DRAWING IS FOR REFERENCE ONLY			



1827 HOBBS DR.
 DELAVAN, WI. 53115
 PHONE: 1-(800)-279-4911
 FAX: 1-(262)-757-7557
 E-MAIL SALES@USTANKER.COM
 WEBSITE: WWW.USTANKER.COM